

HL

HEATING SYSTEMS

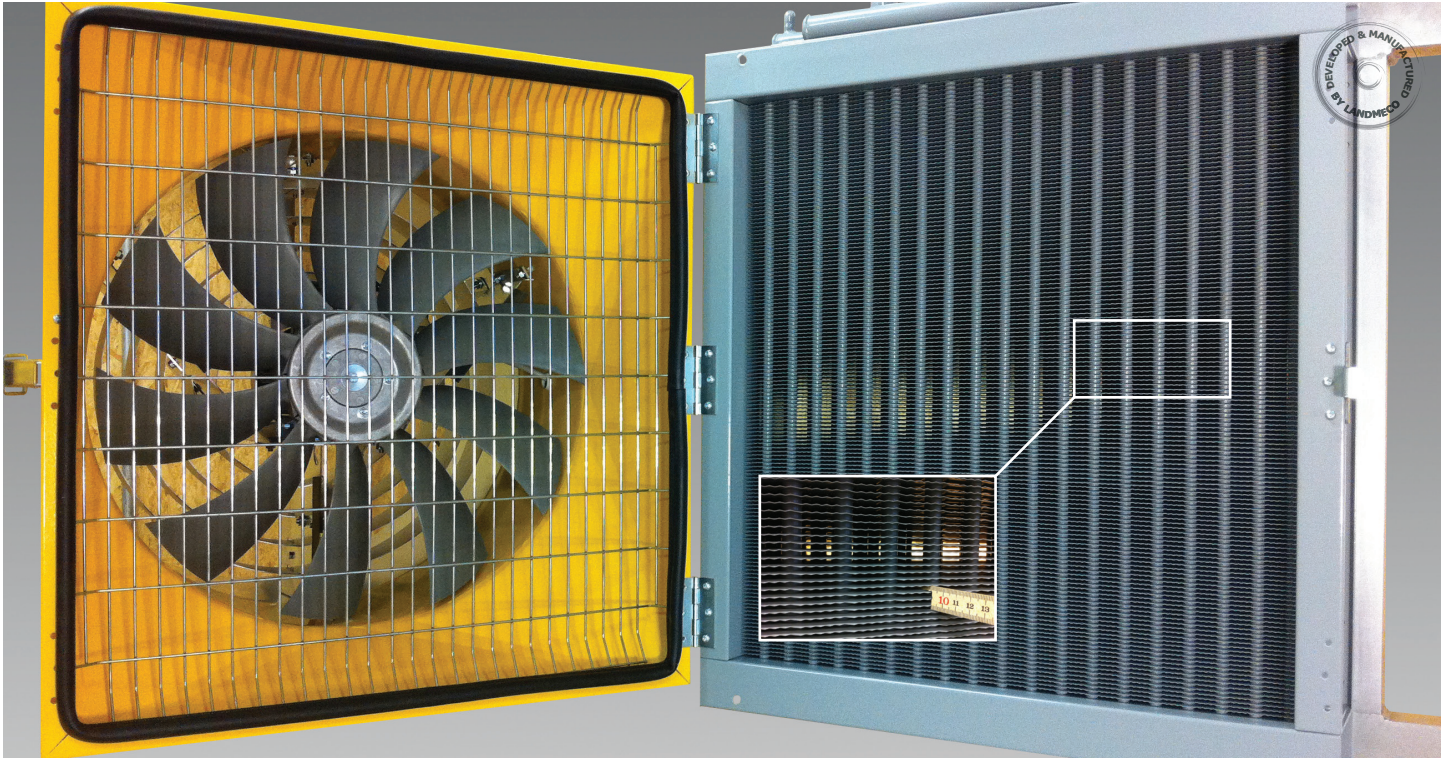

CALORI-AIR



The LANDMECO Calori-Air heating system is specially designed for use in poultry houses or other types of livestock housing in which there is much dust and/or high heating requirements. The heater ribs are therefore more widely spaced than is normal for similar heaters. Also, the fan has a total of 10 blades, ensuring that the Calori-Air is very quiet.

Ventilation supplier

LANDMECO recommends that the final solution be designed in cooperation with the supplier of the ventilation system.

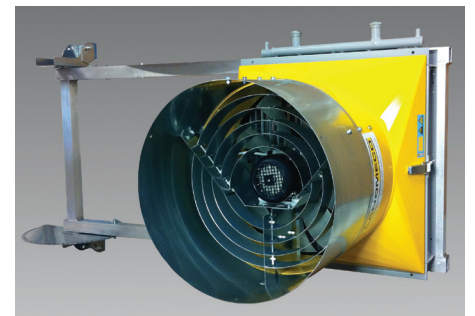

Exceptional output

Heating surfaces are designed on the basis of the latest heating surface technology, and thus extremely efficient in relation to element size.

Easy cleaning

The fan unit is hinged on the heating element so it can be swung completely open. This allows easy access to the heating surface and housing for cleaning purposes. The widely spaced ribs of the heating surface also facilitate cleaning.

INSTALLATION POSSIBILITIES

TRADITIONAL
HEATING



Is recommended as it provides the best possible heat distribution and thus ensures dry litter. As heaters can be raised and lowered by means of a winch, it provides exceptional air circulation. This Calori-Air is available with two different distributor plates respectively in galvanized steel or fiberglass.

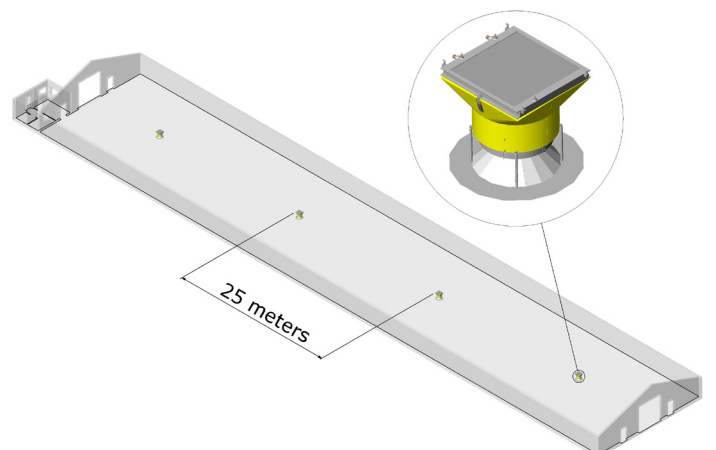

INSTALLATION POSSIBILITIES

GABLE HEATING

2

Gable heating with two air heaters is suitable for use in short houses up to 40-50 metres. Pipes are located on side walls. LANDMECO recommends that this solution is supplemented with air circulation fans, to ensure a suitable climate and dry litter throughout the entire unit.

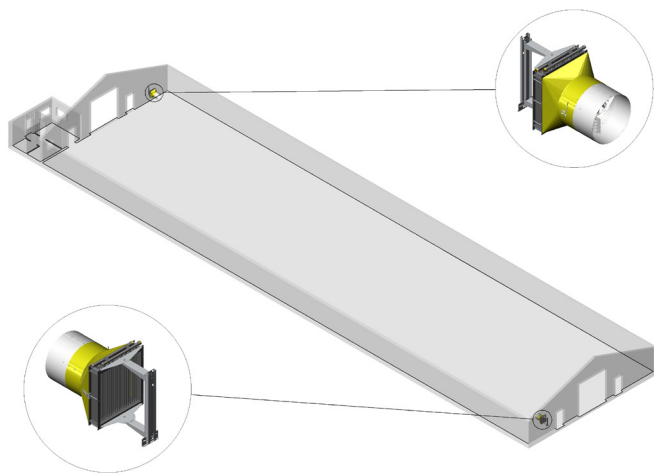

BALANCE HEATING

3

Balance heating with two air heaters is suitable for use in housing units of up to 80-90 metres. Cleaning is easy as the heaters are mounted on swivel arms. This system provides good air circulation.

Balance heating is also available with a 201 cm wall bracket (see balance heating db, 4).

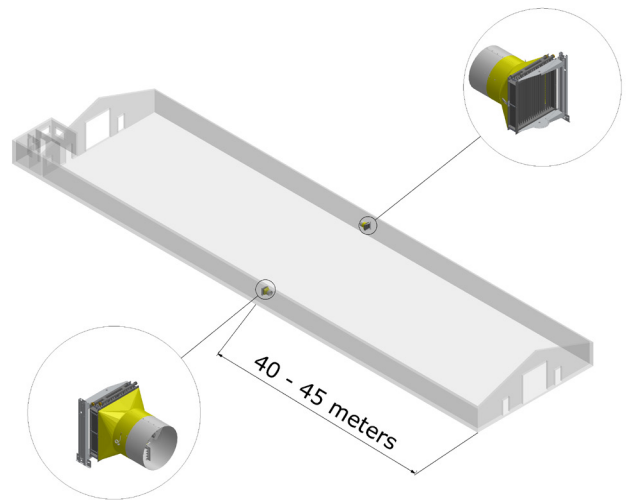

BALANCE HEATING, DB

4

The conditions described under balance heating (3) also apply here. In this system, however, two air heaters are installed on each side wall because of greater housing unit length. This solution is typically used in long housing units of up to 100-110 metres in length.

Balance, db heating is also available with a 84 cm wall bracket (see balance heating, 3).

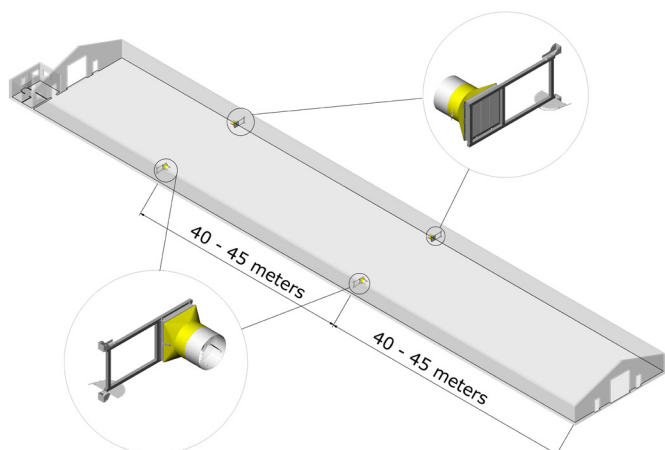

SINGLE-SIDED HEATING

5

In this system, air heaters are only installed on one of the side walls. The system is suitable for housing units of up to 80-90 metres.

The main advantage of this solution is that the boiler room can be positioned in close proximity to both air heaters, thus eliminating the need for extensive piping and making the system both simpler and cheaper.

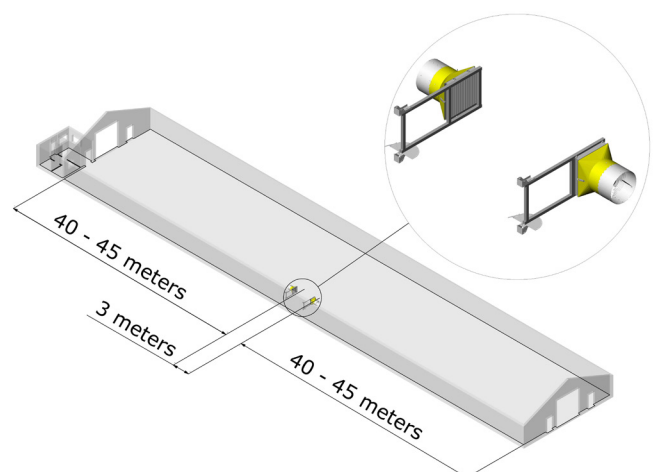

TECHNICAL SPECIFICATIONS

MODEL 91-900	
Heating element thickness	91 mm
Heating element material	Copper tubes and seawater resistant aluminum
Weight excl. water	74 kg
Fan motor	0,55 kW, 900 rpm clixon incl.. Other motor specifications are available on request!
Fan output	7100 m³/h
HxWxD	880x760x680 mm
HxWxD with extension	880x760x920 mm
Water back pressur	0,16 bar
Connection	5/4" BSP
Number of circuits	7

OUTPUT CURVE FOR MODEL 91-900 WITH A FLOW RATE OF 54 L/MIN. VERTICAL INSTALLED*

*The outputs are for installation possibility 2-5.

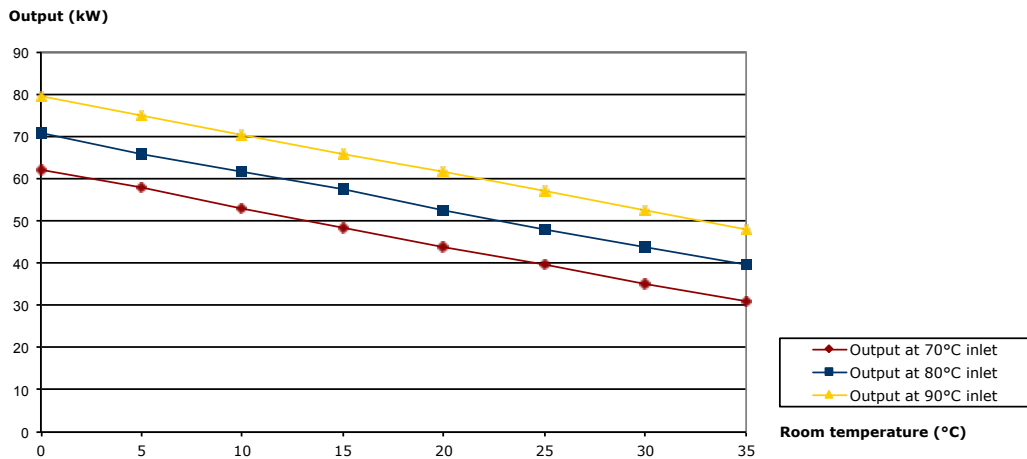

See also LANDMECO brochures on, for example:
(LANDMECO retains the right to alter specifications without notice)



PAN FEEDING
KICK-OFF 160°



PAN FEEDING
KICK-OFF 330°



DRINKING SYSTEMS



AUGERS

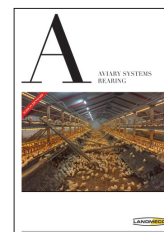

AVIARY SYSTEMS
REARING



BREEDER FEEDING

DEALER

MPA AGRO